

UltraLift Vision Cover Lifter



SMP Specialty Metal Products Inc. 326
 Watline Avenue Mississauga, ON L4Z 1X2
 1-800-597-1343
 www.ultrapoolandspa.com

Top Mount ONLY

Assembly, Installation Instructions & Parts List

PARTS LIST

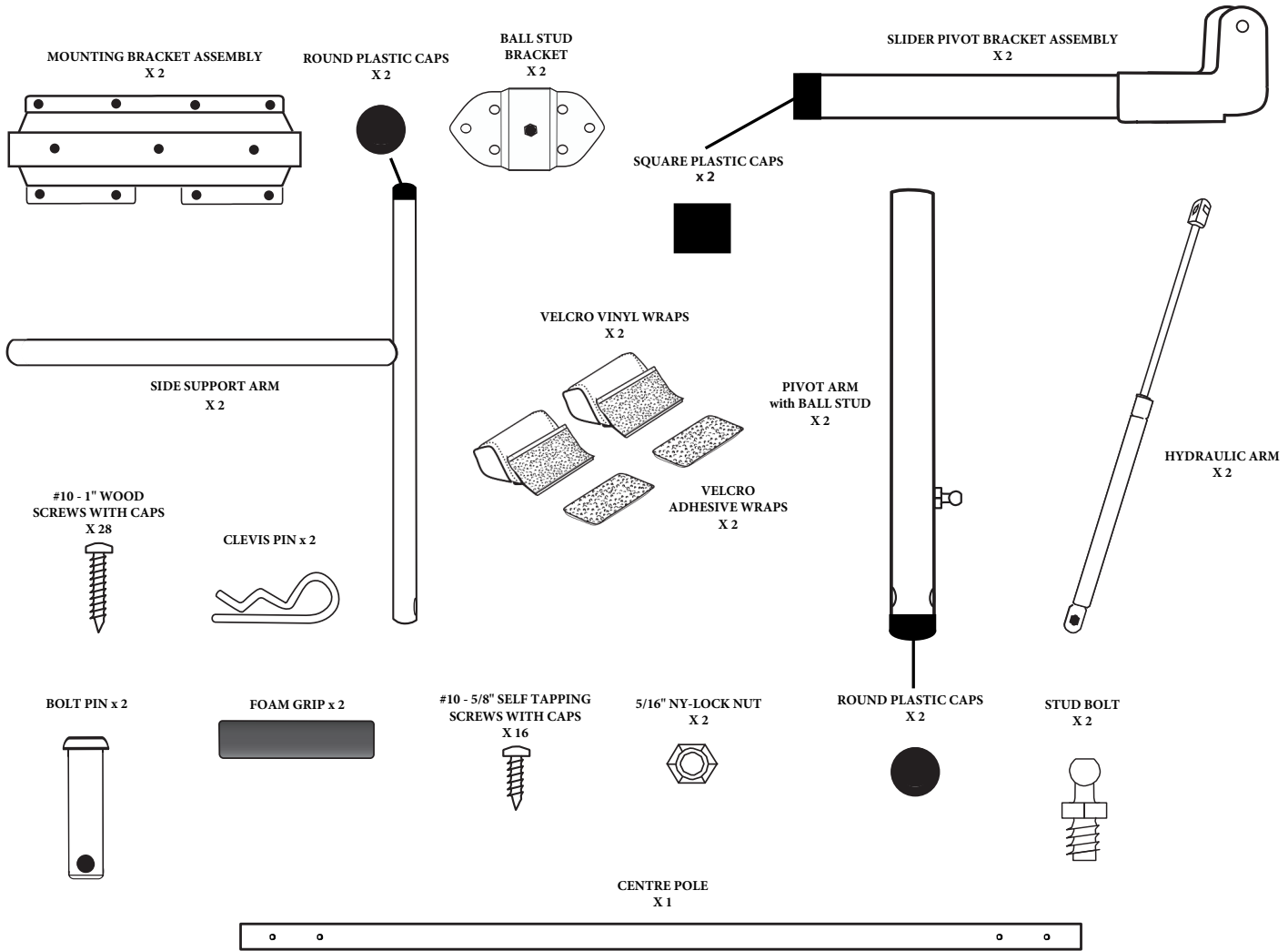

PARTS

- Side Support Arm (x2)
- Mounting Bracket Assembly (x2)
- Slider Pivot Bracket assembly (x2)
- Hydraulic Arm (x2)
- Ball Stud Bracket (x2)
- Center Pole (x1)
- Pivot Arm with Ball Stud (x2)
- Velcro Vinyl Wraps (x2)
- Velcro Adhesive Wraps (x2)
- Round Plastic Caps (x2)

- #10 - 5/8" Self Tapping Screw (x16)
- #10 - 1" Woodscrew (x28)
- #10 Screw Caps (x48)
- 5/16" NY-Lock Nut (x2)
- Foam Grip (x2)
- Square Plastic Caps (x2)
- Round Plastic Caps (x2)
- Stud Bolt (x2)
- Bolt Pin (x2)
- Clevis Pin (x2)

TOOLS LIST

- Phillips screwdriver
- Measuring tape
- Drill
- 1/8 drill bit
- Adjustable wrench

ULTRALIFT VISION COVER LIFTER

Hydraulic Mount Application of the Velcro Tape

NOTE: Adhesive bond strength requires a minimum of 1 hour at temperatures between 68 and 100 degrees F before applying load. This dwell time is important for achieving a firm adhesive bond before using.

Clean and dry the cover before application. You can use any cleaner that will not leave a film or oily surface. We recommend using alcohol prep pads.

Center the Velcro tape along the folding seam of the cover, allowing a minimum of 52" between each Velcro strip. Peel the tape from the backing and press firmly into place.

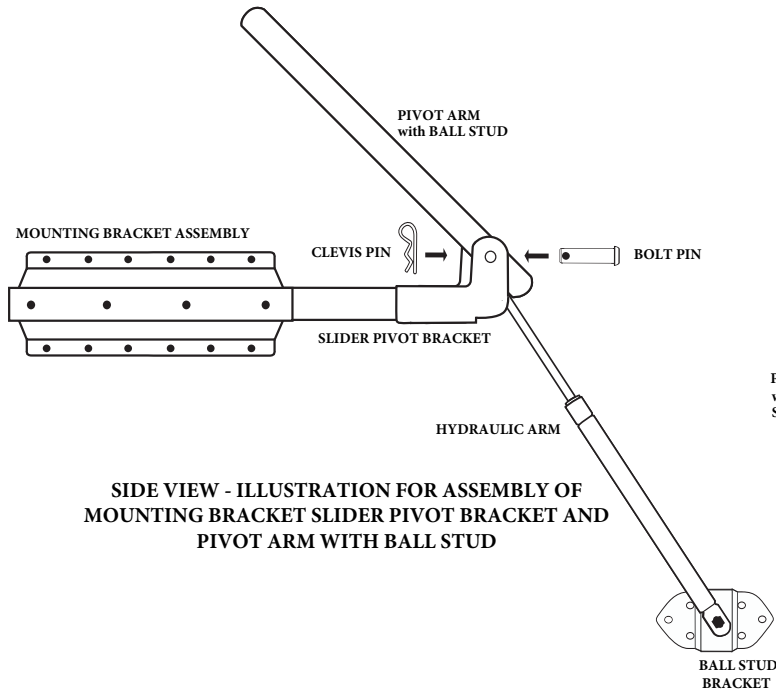
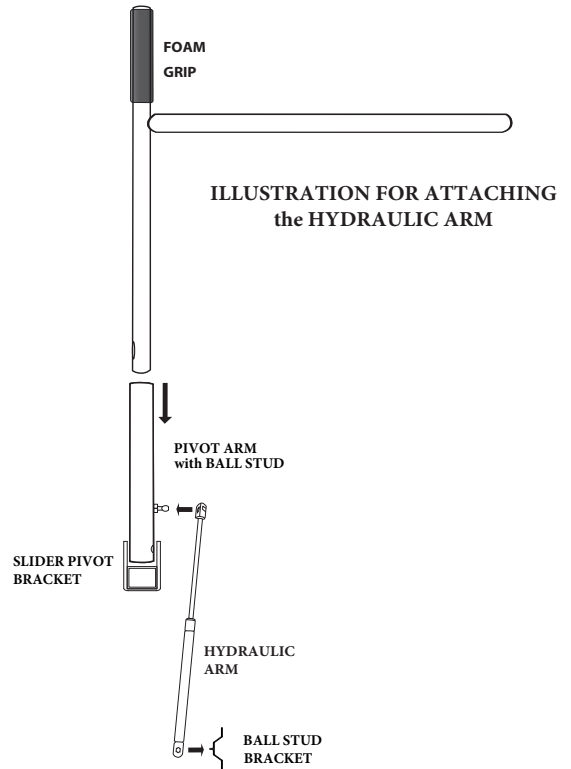
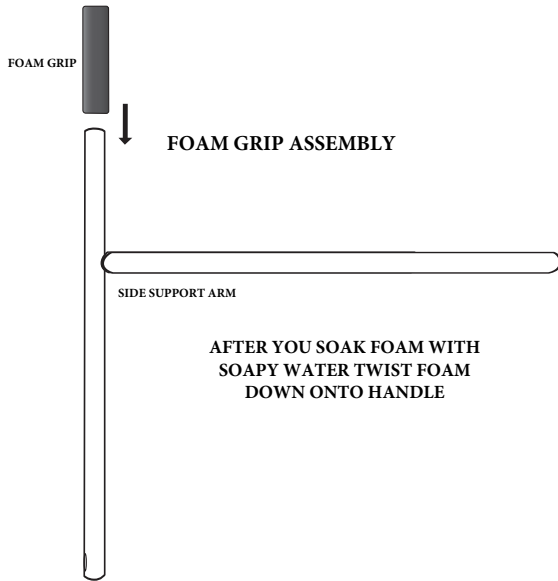

SIDE VIEW - ILLUSTRATION FOR ASSEMBLY OF MOUNTING BRACKET SLIDER PIVOT BRACKET AND PIVOT ARM WITH BALL STUD

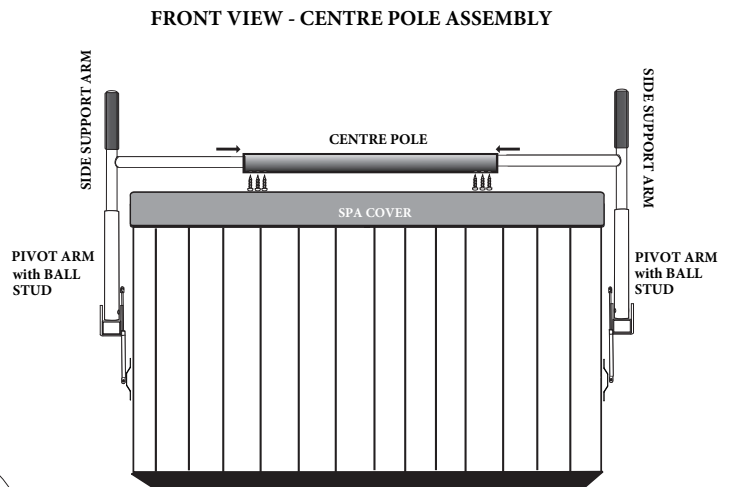

FRONT VIEW - CENTRE POLE ASSEMBLY

ULTRALIFT VISION COVER LIFTER

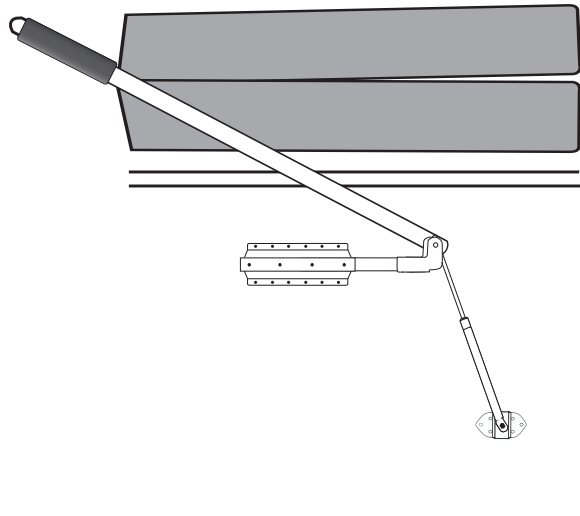

CAUTION:
DO NOT USE
the *UltraLift* in windy conditions.
The spa cover may blow over
and impact the spa user.

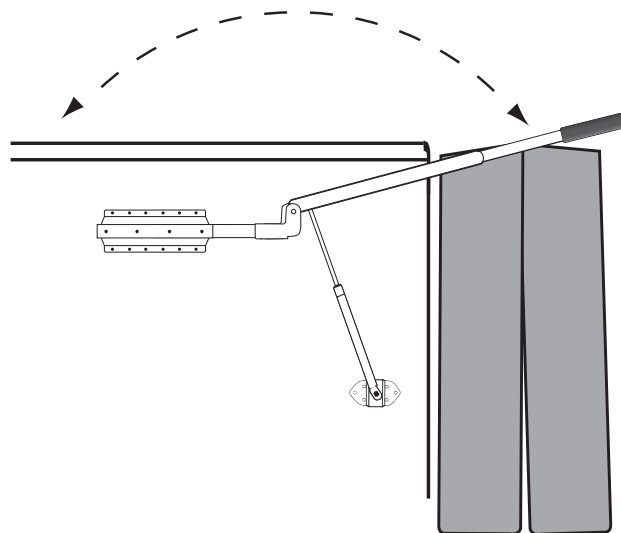
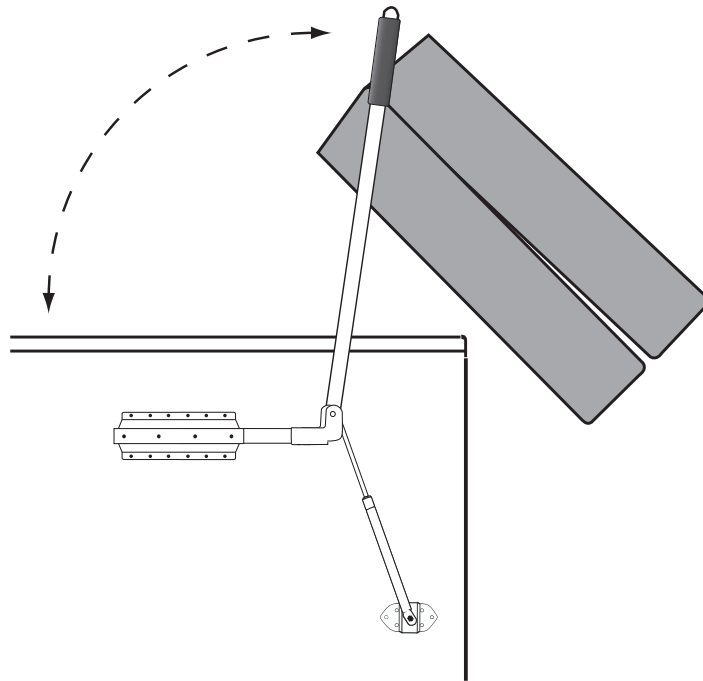

ULTRALIFT VISION COVER LIFTER

Step 1:

Determine the mounting bracket position.....

TO DETERMINE PIVOT LOCATION

		<i>Cover Thickness (Inches)</i>			
		3	4	5	6
<i>Spa Cover Size (Inches)</i>	70	14.5	13.5	12.5	11.5
	72	15	14	13	12
	74	15.5	14.5	13.5	12.5
	76	16	15	14	13
	78	16.5	15.5	14.5	13.5
	80	17	16	15	14
	82	17.5	16.5	15.5	14.5

*For spas up to 7 feet
80 lb Gas spring*

<i>Spa Cover Size (Inches)</i>	84	18	17	16	15
	86	18.5	17.5	16.5	15.5
	88	19	18	17	16
	90	19.5	18.5	17.5	16.5
	92	20	19	18	17
	94	20.5	19.5	18.5	17.5
	96	21	20	19	18
	98	21.5	20.5	19.5	18.5
	100	22	21	20	19

*For spas over 7 feet
110 lb gas
spring*

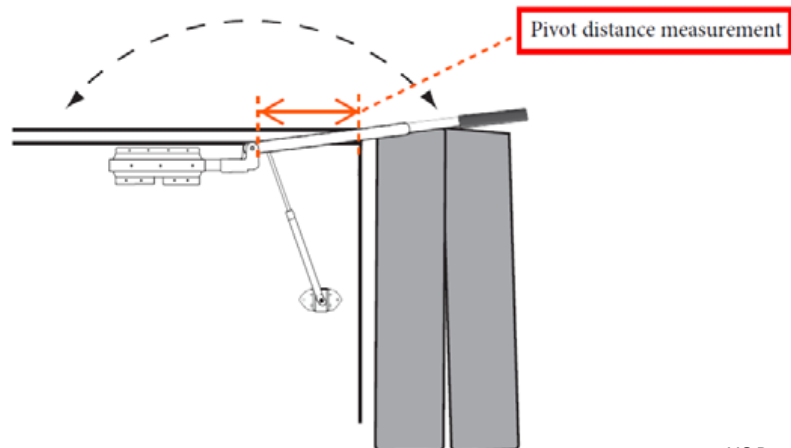

ULTRALIFT VISION COVER LIFTER

Step 2:

Mount the bracket close to the top of the spa, using the longer woodscrews, as shown in the illustration. Slide the slider pivot bracket into the mounting bracket, to the pre-determined position calculated in step 1 and secure to the mounting bracket using the self-tapping screws. Repeat on the other side of the spa.

Step 3:

With the cover in the closed position on the spa, place the centre pole in the middle of the cover along the seam. Slide the longer side of each support arm into both ends of the centre pole. Ensure the cover hook, as shown in the pre-assembly instructions, is on the side support arm and will slide between the cover seam and the middle of the cover.

Step 4:

Slide the pivot arm over the side support arm, so that the ball stud faces the side of the spa. Connect the bottom of the round pivot arm to the slider pivot bracket using the bolt pin and clevis pin.

Step 5:

Ensure the assembly is square and the centre pole sits 1" from the cover's centre seam.** , on the lifter side. We recommend rotating the centre pole so that the screws are inserted horizontally, and secure the centre pole and the pivot arms to the corner support arms using self-tapping screws.

Step 6:

Slide the spring-loaded end piece of the hydraulic arm over the ball stud on the pivot arm. Attach the opposite end over the ball stud on the smaller mounting bracket.

Step 7:

To find the location of the smaller pivot bracket, the pivot arm must be in line with the hydraulic arm. This may require lifting the cover, to achieve the optimal position. The smaller bracket should be placed at the edge of the radius corner to ensure the bracket is secured into the tub frame, which is usually found at the end of the side panel.



by SMP Specialty Metal Products

1 YEAR LIMITED WARRANTY

The Warranty:

SMP Specialty Metal Products Inc. warrants to you (the Original Retail Purchaser) that, for the stated Warranty Term, SMP Specialty Metal Products Inc. will repair or replace any part of UltraLift Spa Cover Lifter which is defective in material or workmanship. It is important that you report to the Retailer from whom you purchased UltraLift, any defects as soon as they are detected. If it is impractical to report any defects to the Retailer, contact:

SMP Specialty Metal Products Inc.
326 Watline Ave.
Mississauga, ON L4Z 1X2 CANADA

Ph: 800-597-1343
info@theultralift.com

After notification, you may be asked to return UltraLift to the Retailer from whom it was purchased or ship it back to SMP Specialty Metal Products Inc. for inspection. If you are requested to return UltraLift to SMP Specialty Metal Products Inc., you will be responsible for the cost of such transportation. SMP Specialty Metal Products Inc., after repair or replacement, will pay the cost of return shipping to you or to the Retailer from whom you purchased the UltraLift.

NO RETURNS OF MERCHANDISE WILL BE ACCEPTED UNTIL A RETURN AUTHORIZATION NUMBER HAS BEEN ISSUED TO YOU BY SMP Specialty Metal Products Inc.

Warranty Term:

This warranty lasts 1 year from the date of purchase of UltraLift by the original retail purchaser. Warranty will terminate at the end of the 1 year period or at the time ownership of UltraLift transfers, whichever occurs first.

Limitations and Exclusions:

The following clauses that are listed may reduce SMP Specialty Metal Products Inc. responsibility under this warranty.

Implied Warranties:

SMP Specialty Metal Products Inc. makes no implied warranties (warranties the law sometimes implies to have been given by the seller even though they are not described in writing) of merchantability or fitness for a particular purpose. Some provinces/states do not allow an exclusion or limitation on how long an implied warranty lasts, so this exclusion may not apply to you.

Proof of Purchase:

Proof of purchase by the Original Retail Purchaser is required for Warranty Consideration.

Commercial Use:

This warranty is in effect only when UltraLift has been purchased for private residential use. Commercial use is not covered under this warranty.

Accidents, Abuse and Normal Wear:

This warranty does not cover damage resulting from negligence, abuse, normal wear or accidents. Examples of accidental and abusive damage include, but are not limited to the following:

1. Use of abrasive or unapproved cleaners that could cause surface damage.
2. Subjection to solvents or other chemicals which could deteriorate painted surfaces.
3. Use for any purpose other than as a spa cover lifter.

Consequential Damages:

SMP Specialty Metal Products Inc. will not be liable for any loss, expense, or damage other than to UltraLift, that may result from a defect in materials or workmanship. (Some provinces/states do not allow the exclusion or limitation of incidental or consequential damages, so the above mentioned limitation may not apply to you.)

Your Warranty Rights:

This warranty gives you specific legal rights and you may also have other rights which vary from province/state/province. Except for such other rights, the remedies provided under this warranty state the limit of SMP Specialty Metal Products Inc.'s responsibilities.